

DATA SHEET

GAUSSMETER, Model 5200 Series

05 Specifications

Characteristics		
Model:	5270	5280
Basic DC accuracy	2%	1.1%
Frequency bandwidth	DC-20 kHz	DC-25 kHz
Update rate:		
Display	10 updates / sec.	10 updates / sec.
Analog	100K samples / sec.	100K samples / sec.
Ranges:		
Ultra-low range	1 G	1 G
Low range	200 G	300 G
Mid-range	2 kG	3 kG
High range	20 kG	30 kG
Resolution:		
Ultra-low range	1 mG	1 mG
Low range	0.1 G	0.1 G
Mid-range	1 G	1 G
High range	10 G	10 G
Readings	Gauss, Tesla, Amps/meter	Gauss, Tesla, Amps/meter
Operating temperature	0°C to 50°C	
Storage temperature	-25°C to 70°C	
Meter weight	0.98 lbs. (443 g)	
Size	8.00" x 3.85" x 1.87" (20.32 cm x 9.78 x 4.75 cm)	
Compliance	EN IEC 61326-1:2021	
Drop Test	1 Meter drop per IEC 61010-1: 2010	

06 Outline details

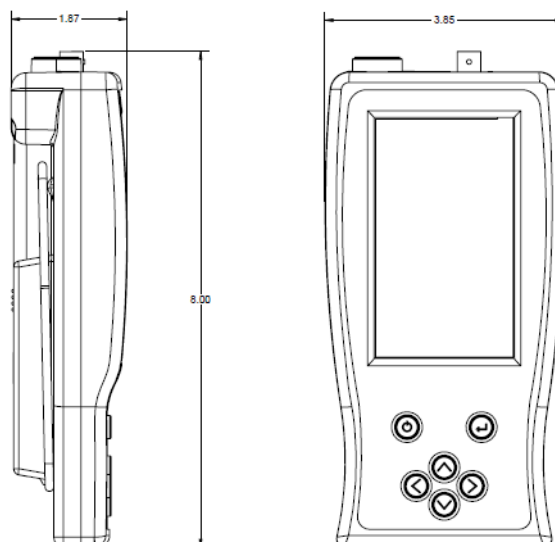

Note: Due to continuous process improvement, specifications are subject to change without notice.